

Retroreflective sensor

GLV18-55-G/59/102/115

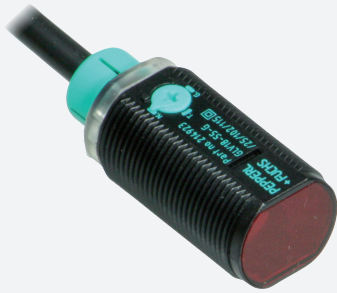

- Efficient Line in a short M18 plastic housing for standard applications
- Two devices in one: choice of either clear object detection or retroreflective operating mode with a large detection range
- 4 LEDs indicator for 360° visibility
- Optimized potentiometer design for a clear control button layout in the application
- DC voltage version

Retroreflective sensor for glass detection, M18 threaded housing design, plastic housing, front optical face, 2.5 m detection range, red light, dark on, DC version, NPN output, fixed cable



Function

The GLV/GLK18 series sensors help improve the efficiency of machines and systems. The design of the M18 plastic housing, the connection technology, and sensor properties are highly standardized. Concentrating on the key sensor requirements has produced a robust and reliable product series for DC and AC/DC voltage systems without any over-engineering. The mounting set included in the scope of delivery and the optimized potentiometer design ensure fast assembly and easy configuration.

Dimensions

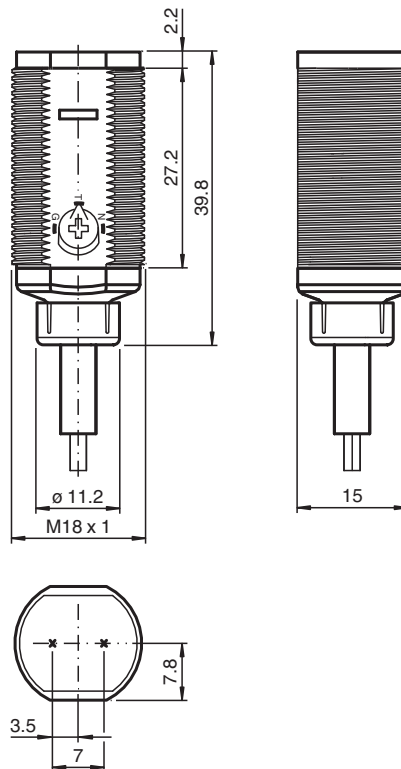

Release date: 2020-11-06 Date of issue: 2020-11-06 Filename: 214924_eng.pdf

Refer to "General Notes Relating to Pepperl+Fuchs Product Information".

Pepperl+Fuchs Group
www.pepperl-fuchs.com

USA: +1 330 486 0001
fa-info@us.pepperl-fuchs.com

Germany: +49 621 776 1111
fa-info@de.pepperl-fuchs.com

Singapore: +65 6779 9091
fa-info@sg.pepperl-fuchs.com

PF PEPPERL+FUCHS

Technical Data

General specifications		
Effective detection range		0 ... 2.5 m in glass mode; 0 ... 5 m in normal mode
Reflector distance		0 ... 2.5 m in glass mode; 0 ... 5 m in normal mode
Threshold detection range		6.5 m
Reference target		reflector C110-2
Light source		LED
Light type		modulated visible red light , 640 nm
Polarization filter		yes
Diameter of the light spot		approx. 370 mm at 6.5 m ; 50 mm at 1 m
Angle of divergence		approx. 2 °
Optical face		frontal
Ambient light limit		30000 Lux
Functional safety related parameters		
MTTF _d		1260 a
Mission Time (T _M)		20 a
Diagnostic Coverage (DC)		0 %
Indicators/operating means		
Operation indicator		LED green, statically lit Power on, blinking with 2 Hz or 4 Hz in Teach-In mode
Function indicator		LED yellow: In retro-reflective mode: Lights up when light beam is free; flashing if signal is short of function reserve, off when light beam is interrupted In glass-mode: Lights up when light beam is free; flashing if further compensation is impossible; off when light beam is interrupted
Control elements		potentiometer for Teach-In and Mode selection
Contrast detection levels		18 % - clear glass bottles
Electrical specifications		
Operating voltage	U _B	10 ... 30 V DC
No-load supply current	I ₀	< 15 mA
Output		
Switching type		dark on
Signal output		1 NPN, short-circuit protected open collector
Switching voltage		max. 30 V DC
Switching current		max. 100 mA
Voltage drop	U _d	≤ 1.5 V DC
Switching frequency	f	1 kHz
Response time		≤ 0.5 ms
Conformity		
Product standard		EN 60947-5-2
Approvals and certificates		
Protection class		II, Rated insulation voltage ≤ 50 V AC with pollution degree 1-2 according to IEC 60664-1
UL approval		cULus Listed, Class 2 Power Source
CCC approval		CCC approval / marking not required for products rated ≤36 V
Ambient conditions		
Ambient temperature		-25 ... 60 °C (-13 ... 140 °F)
Storage temperature		-40 ... 70 °C (-40 ... 158 °F)
Mechanical specifications		
Degree of protection		IP67
Connection		2 m fixed cable
Material		
Housing		PC
Optical face		PMMA
Cable		PVC

Release date: 2020-11-06 Date of issue: 2020-11-06 Filename: 214924_eng.pdf

Refer to "General Notes Relating to Pepperl+Fuchs Product Information".

Pepperl+Fuchs Group
www.pepperl-fuchs.com

USA: +1 330 486 0001
fa-info@us.pepperl-fuchs.com

Germany: +49 621 776 1111
fa-info@de.pepperl-fuchs.com

Singapore: +65 6779 9091
fa-info@sg.pepperl-fuchs.com

 PEPPERL+FUCHS

Technical Data

Mass	approx. 75 g
------	--------------

Connection Assignment

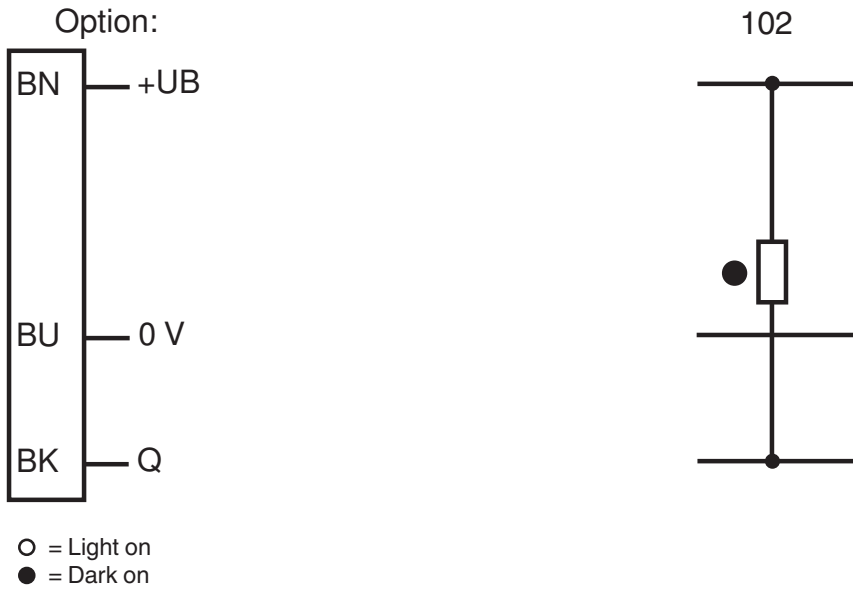

Assembly

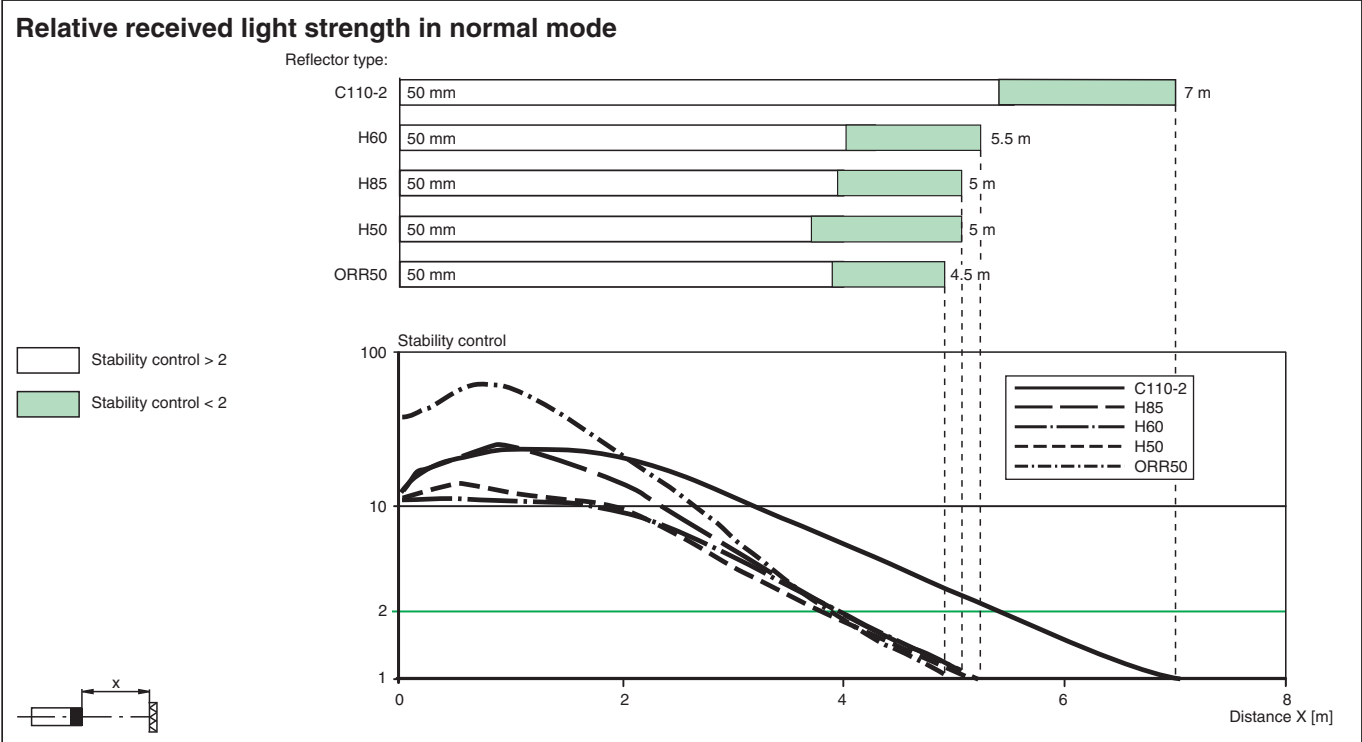
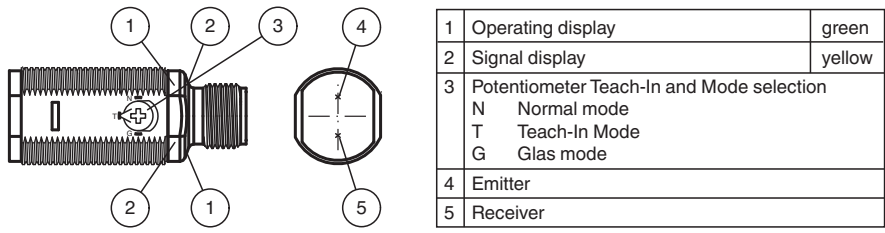

Release date: 2020-11-06 Date of issue: 2020-11-06 Filename: 214924_eng.pdf

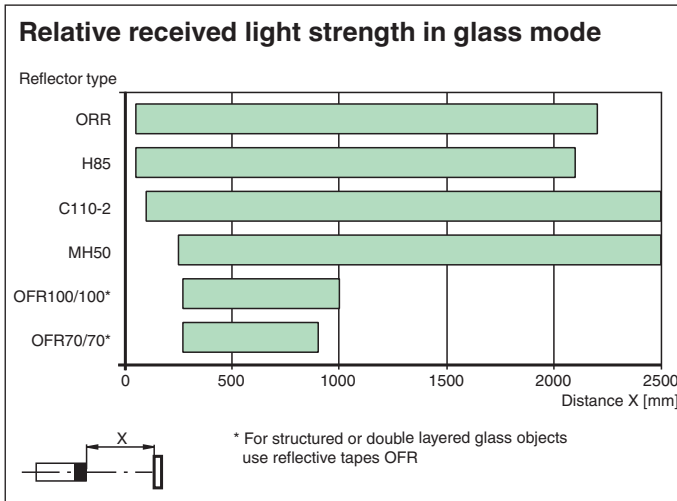

Application



Accessories

	CPZ18B03	Mounting Bracket with swivel nut
	BF 18	Mounting flange, 18 mm
	BF 18-F	Plastic mounting adapter, 18 mm
	BF 5-30	Universal mounting bracket for cylindrical sensors with a diameter of 5 ... 30 mm
	REF-C110-2	Reflector, round ø 84 mm, central mounting hole
	REF-H60	Reflector, rectangular 40.5 mm x 60 mm, mounting holes
	REF-H50	Reflector, rectangular 51 mm x 61 mm, mounting holes, fixing strap

Release date: 2020-11-06 Date of issue: 2020-11-06 Filename: 214924_eng.pdf

Accessories

Other suitable accessories can be found at www.pepperl-fuchs.com

Application

Packaging industry:

- Presence checks, track loading, completeness checks, stack height control

Material handling

- Presence checks, target sensor, profile checks, trigger sensor

Automatic doors, gates and access systems, elevator:

- Secure detection for automatic door and gate systems
- Monitoring function in turnstiles
- Closing edge monitoring in elevators